

## 1064nm 30mW DFB Butterfly Laser Diode

### 1. Features:

- Multi-Quantum Well (MQW) distributed feedback(DFB) lasers;
- Built-in thermistor, TEC and isolator;
- Hi1064 SM or PM980 fiber pigtail;
- Operating temperature -20~ +65°C.

**Reliability:** Telcordia GR-468. RoHS.

### 2. Applications:

- Optical fiber communication;
- Optical instrument;
- Optical fiber sensor;
- Light source.

### 3. Absolute Maximum Ratings:

Parameter	Symbol	Condition	Min.	Max.	Unit
Laser forward current	$I_F$	-	-	400	mA
Reverse voltage	$V_{RLD}$	CW	-	-2.0	V
TEC Voltage	$V_{TEC}$	-	-4.2	4.2	V
TEC Current	$I_{TEC}$	-	-1.8	1.8	A
ESD Voltage	-	-	500	-	V
Operating temperature	$T_{OP}$	Case temperature	-20	+65	°C
Storage temperature	$T_{STG}$	Ambient temperature	-40	+85	°C
Lead solder temperature/Time	-	-	260/10		°C/S

### 4. Optical-Electro Characteristics(T=25°C, $I_F = I_{OP}$ ):

Parameter	Symbol	Condition	Min.	Typ.	Max.	Unit
Operating wavelength	$\lambda_C$	CW, 25°C, $I_{OP}=200\text{mA}$	1063	1064	1065	nm
Optical output power	$P_F$	SM Fiber	30	-	-	mW
Threshold current	$I_{TH}$	25°C, $I_{OP}=200\text{mA}$	-	20	30	mA
Operating current	$I_{OP}$	CW	-	-	200	mA
Operating voltage	$V_{OP}$	25°C, $I_{OP}=200\text{mA}$	-	-	2.7	V
Side mode suppression ratio	SMSR	-	40	-	-	dB
Spectral width (-20 dB)	$\Delta\lambda$	-	-	0.1	1.0	nm
Optical isolation	$I_{SO}$	-	-	30	-	dB
Slope efficiency	$\eta$	-	-	0.28	-	mW/mA
Monitor current	$I_{MON}$	$V_R = 5\text{V}$ , $I_{OP}=200\text{mA}$	500	-	1250	$\mu\text{A}$

MPD Dark current	$I_D$	$V_R=5V$	-	-	200	nA
Thermistor resistance	$R_{TH}$	25°C	9.5	10	10.5	kΩ
Thermistor B-value	$\beta$	25°C/85°C	-	3950	-	K
TEC Operation temperature	$T_{OP}$	$I_{OP}=200mA$	15	-	40	°C

**5. Package Drawing&PIN-OUT Definition(Unit:mm):**

Type 2

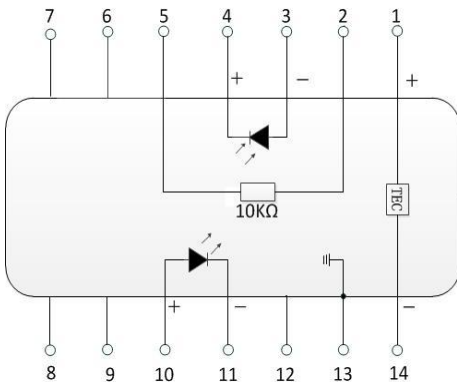
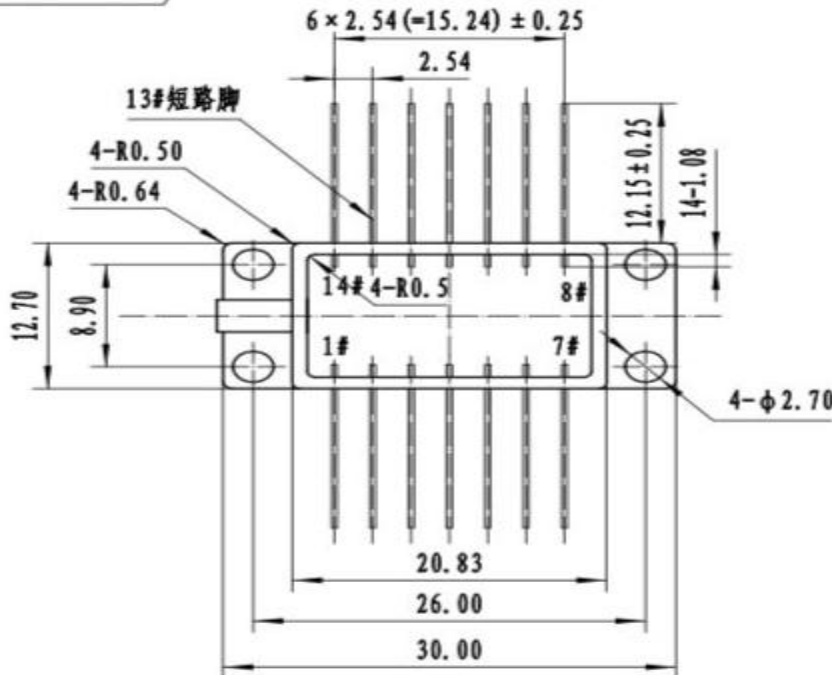
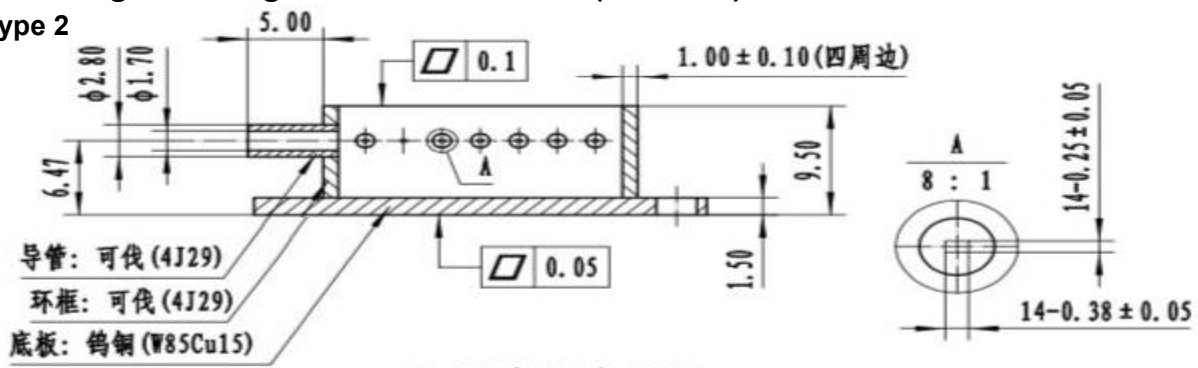

PIN	Description	PIN	Description
1	TEC(+)	14	TEC(-)
2	Thermistor	13	Case Ground
3	PD Monitor Anode (-)	12	NC
4	PD Monitor Cathode (+)	11	Laser Cathode(-)
5	Thermistor	10	Laser Anode(+)
6	NC	9	NC
7	NC	8	NC