

## 1310nm Semiconductor Optical Amplifier

### 1. Description:

The Semiconductor Optical Amplifier (SOA) product series, is primarily used for optical signal amplification and can significantly increase the output optical power. The products feature high gain, low power consumption, and polarization maintenance, among other characteristics, and are fully processable with domestically controllable technology.

### 2. Features:

- 40G and 100G C-Band blocking shutter or modulation;
- 14PIN Butterfly package;
- Low Noise Figure & Low polarization dependence;
- SMF-28e fiber with FC/APC connector.

**Reliability:** Telcordia GR-468. RoHS

### 3. Applications:

- Loss compensation for fiber optical connection and switch;
- WDM fiber optical networks;
- MOPA (Master Oscillator Power Amplifier) laser.

### 4. Electro-Optical Characteristics(25°C laser temperature):

Parameter	Symbol	Condition	Min.	Typ.	Max.	Unit
Operating wavelength	$\lambda_{PEAK}$	25°C, $P_{IN}=-15dBm$	-	1310	-	nm
ASE Centre wavelength	$\lambda_{ASE}$	25°C, $I_F=120mA$	-	1310	-	nm
-3dB Gain Bandwidth	$\Delta \lambda$	$P_{IN}=0dBm$	-	65	-	nm
Saturation Optical Power	$P_{MAX}$	$I_F=120mA$ , $P_{IN}=5dBm@1310nm$	-	15	-	dBm
Small Signal Gain	SSG	$I_F=120mA$ , $P_{IN}=-20dBm@1310nm$	-	25	-	dB
Polarization dependent gain	PDG	25°C, $I_F=120mA$	-	0.5	1.0	dB
Operating current	$I_F$	-	-	250	400	mA
Forward voltage	$V_F$	-	-	1.2	1.5	V
Noise Figure	NF	25°C, $I_F=120mA$ , @1310nm	-	7	9	dB
TEC Current	$I_{TEC}$	-	-	-	1.8	A
TEC Voltage	$V_{TEC}$	-	-	-	3.4	V
Thermistor resistance	$R_{therm}$	$T=25^\circ C$	9.5	10	10.5	K $\Omega$
Thermistor current	$I_{therm}$	-	-	-	5	mA
Total power	P	-	-	-	4	W

Operating case temperature	T <sub>OP</sub>	I=I <sub>F</sub>	-10	-	70	°C
Storage temperature	T <sub>S</sub>	-	-40	-	85	°C

**5. Package drawing&PIN-OUT Definition(Unit:mm):**

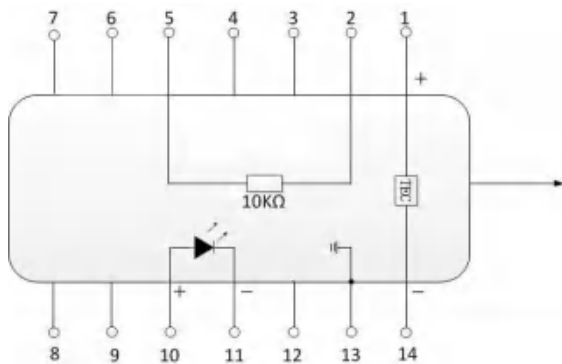
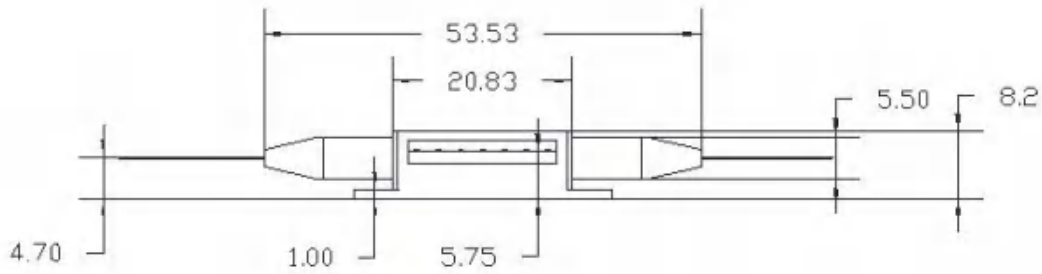
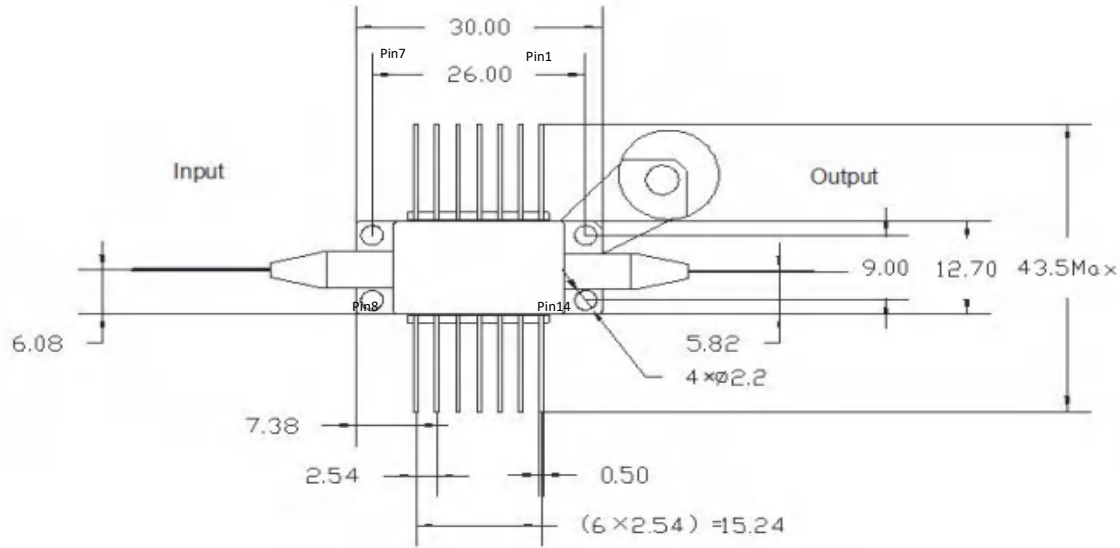

PIN	Description	PIN	Description
1	TEC(+)	14	TEC(-)
2	Thermistor	13	Case Ground
3		12	NC
4		11	Laser Cathode (-)
5	Thermistor	10	Laser Anode (+)
6	NC	9	NC
7	NC	8	NC

**6. Typical Characteristic Curve:**

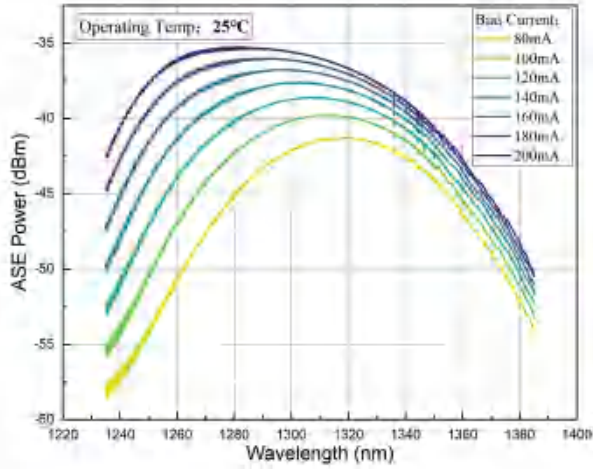

**ASE Spectrum**

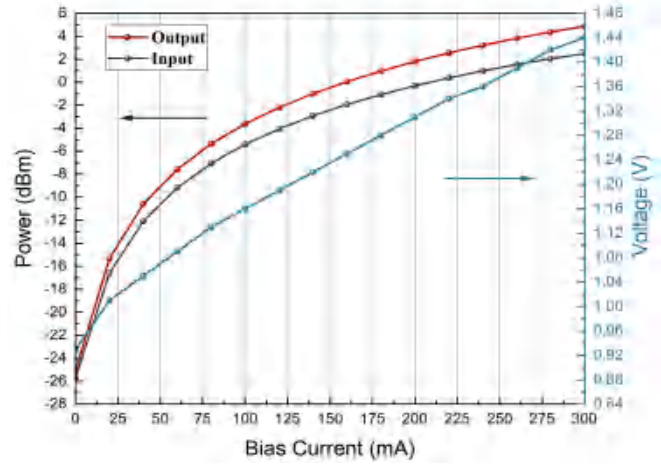

**ASE LIV characteristics**

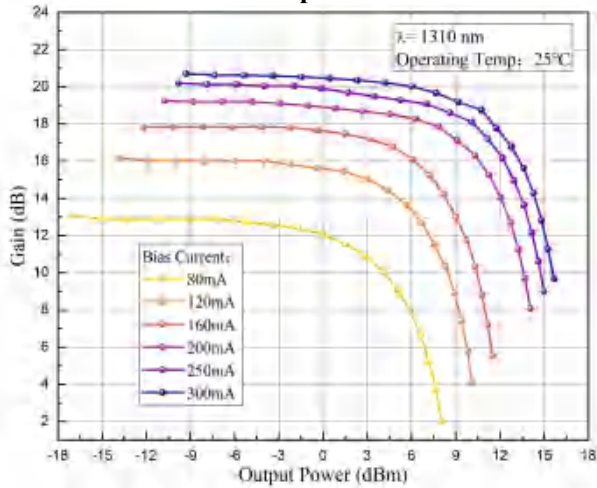

**Gain vs. Output power**

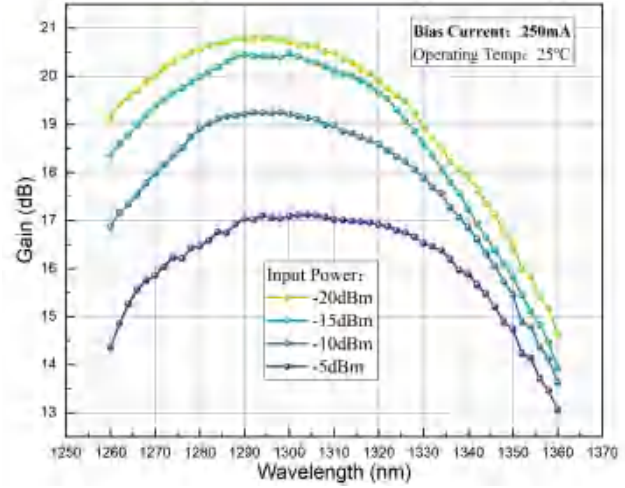

**Gain Spectrum**

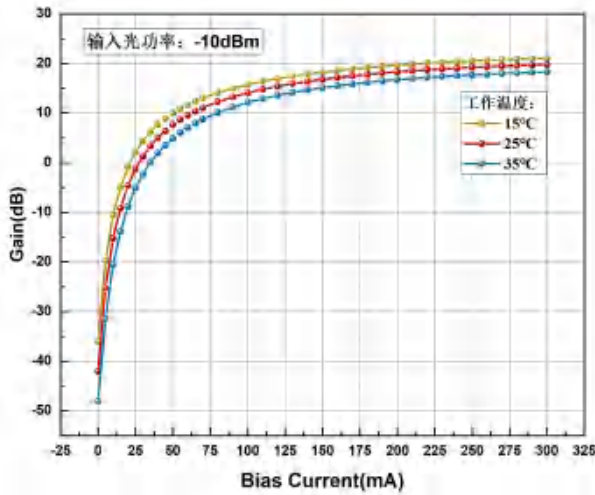

**Gain@different temperature**

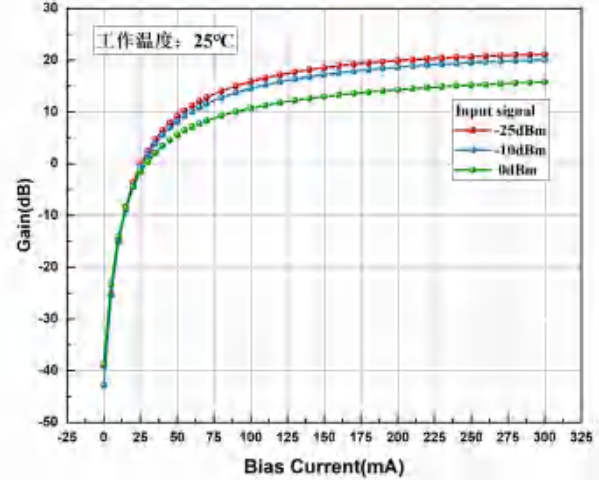

**Gain@different input power**